

WCJ - 1.2 HRS

506-1908-002-1-59

NOTICE: WHEN GOVERNMENT DRAWINGS, SPECIFICATIONS, OR OTHER DATA ARE USED FOR ANY PURPOSE OTHER THAN IN CONNECTION WITH A DEFINITELY RELATED GOVERNMENT PROCUREMENT OPERATION, THE UNITED STATES GOVERNMENT THEREBY INCURS NO RESPONSIBILITY NOR ANY OBLIGATION WHATSOEVER; AND THE FACT THAT THE GOVERNMENT MAY HAVE FORMULATED, FURNISHED, OR IN ANY WAY SUPPLIED THE SAID DRAWINGS, SPECIFICATIONS, OR OTHER DATA IS NOT TO BE REGARDED BY IMPLICATION OR OTHERWISE AS IN ANY MANNER LICENSING THE HOLDER OR ANY OTHER PERSON OR CORPORATION, OR CONFERRING ANY RIGHTS OR PERMISSION TO REPRODUCE, USE, OR SELL ANY PATENTED INVENTION THAT MAY IN ANY WAY BE RELATED THEREBY.

NOTE:

*FOR INFORMATION ONLY
CONTRACTOR MUST AT ALL
OPTIONAL...
THESE PROCEED...

*SWE APPROVAL		REVISIONS			
SYM	PR10042-5	SYM	DESCRIPTION	DATE	APPROVAL
		A ₂	A ₁ -MS20450C8B10 WAS SM-B-178935-2 A ₂ -ADDED APPL. SM-D-248975, SM-D-343600, SC-DL-248775.	9 OCT. 59	42428-PC-59-A1-51 REV'D.
B ₃	CA.84589	B ₃	B ₁ -NOTE 2 WAS SUPPLIED BY CHICAGO RIVET & MACH. CO. B ₂ -MS 20450C8B10 WAS SM 2045068B10. B ₃ -43P205107 WAS 43P 20517.	24 DEC 59	42428-PC-59 REV'D. PME

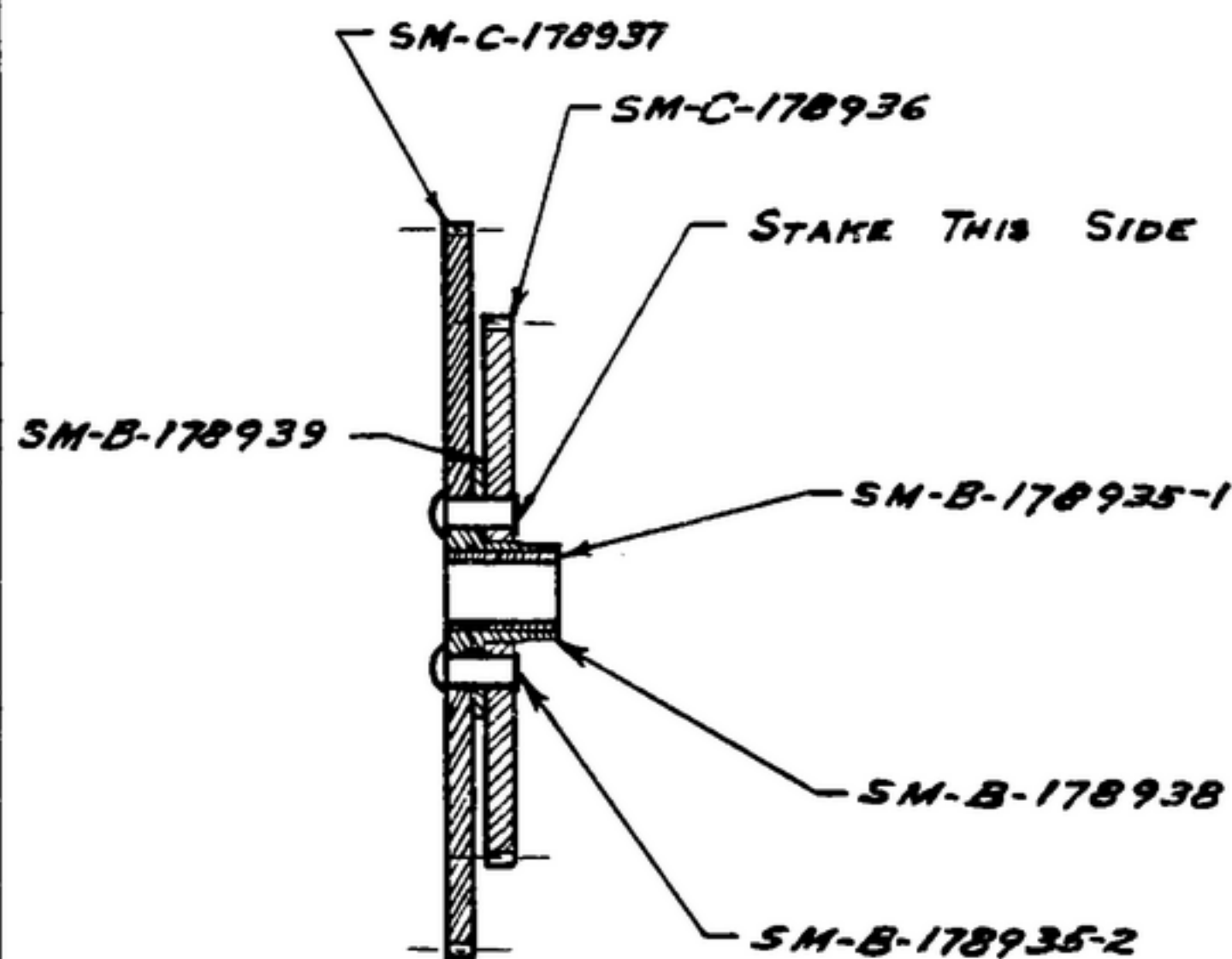

1-SUPPLIED BY BOUND BROOK OIL-LESS BEARING CO, BOUND BROOK, NEW JERSEY, OR EQUAL.

- (B₁) 2.-
3-PRESS GEARS ON HUB COUNTER SINK SIDE SNUG AGAINST SHOULDER, PRESS BEARING FLUSH AT ONE END, MACHINE OPPOSITE END TO AN OVERALL LENGTH OF .480 ±.002 BURNISH BEARING TO .250 ±.0005.

*SWE. PART NO.	REQD	PART NO.	DESCRIPTION	MATL	MATL SPEC
			2 MS20450C8B10 RIVETS, 1/8 DIA X 5/16 LG. BRASS		
(B ₂)		43P205107	1 SM-B-178935-1 BEARINGS, C2505B0515		1
(A ₁)			1 SM-B-178939 RING		
(B ₃)			1 SM-B-178938 HUB		
			1 SM-C-178937 GEAR		
			1 SM-C-178936 GEAR		

LIST OF MATERIAL

UNLESS OTHERWISE SPECIFIED DIMENSIONS ARE IN INCHES TOLERANCES ON FRACTIONS DECIMALS ANGLES		AUTHENTICATION DRAWN 21032-PH-50-93 TRACED PHOTO CHECKED [Signature] VERIFIED P.D.B.R. APPROVED P.D.B.R. REVIEWED PME DATE 4-AUG-53		GEAR ASSY	SIGNAL CORPS ENGINEERING LABORATORIES FORT MONMOUTH NEW JERSEY
(A ₂) SM-D-248975					
SM-D-343600	SM-D-248775				
SM-D-178900	SC-DL-178467				
NEXT ASSY	USED ON				
APPLICATION					

WHEN REFERRING TO THIS DRAWING STATE DRAWING NO., APPLICABLE ISSUE SYMBOL, IF ANY, AND DATE